

## CARACTÉRISTIQUES

- Cuve ronde ou cuve rectangulaire.
- Taloches en PVC.
- Cuve avec bague et couteaux en inox.
- Sur roulettes avec freins.

## FEATURES

- Round bowl or rectangular bowl.
- Press-segments in PVC.
- Bowl with stainless-steel ring and blades.
- On castors with locking system.

## EIGENSCHAPPEN

- Ronde kuip of rechthoekige kuip.
- Drukvoeten in PVC.
- Kuip met roestrijstalen ring en messen.
- Met zwenkwielen met rem.



VERSION  
**2.0**

2 YEARS  
WARRANTY



20 divisions: 100 - 950 gr.  
 20 divisions: 100 - 950 gr.  
 20 verdelingen: 100 - 950 gr.

▪ Poignées de position.  
 Position handles.  
 Verplaatshendels.

▪ Lames et cuve en Inox.  
 Stainless steel bowl and blades.  
 RVS kuip.en messen

▪ Remontée automatique  
 des couteaux.  
 Automatic blade lifting system.  
 Automatische messenlift.

Option chassis en Inox  
 Option stainless steel body.  
 Optie RVS behuizing.



Silencieux.  
 Low noise.  
 Stil.

▪ Sur roulettes avec freins.  
 On castors with locking system.  
 Met zwenkwielen.met rem.



Accès facile pour le nettoyage.  
 Easy access for cleaning.  
 Onderhoudsvriendelijk.

Moteur et pompe à l'abri  
 de la poussière et de la pâte.  
 Motor and pump protected from  
 dust and dough intrusions.  
 Motor en pomp beschermd tegen  
 mogelijk contact met stof en deeg.

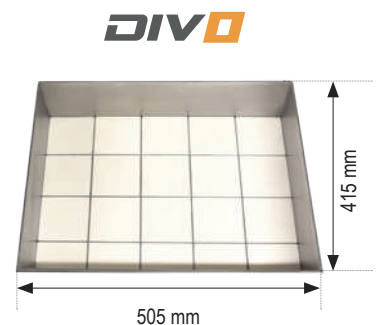

Cadre en fonte d'aluminium avec grilles interchangeables

Cast aluminum frame with interchangeable grids.

Gegoten aluminium frame met verwisselbare roosters.



Fermeture anti-projection de farine.

Anti-flour projection closure.

Anti-bloemprojectie sluiting.

**Pour des pâtes très hydratées.**

**For highly hydrated dough.**

**Voor hoog gehydrateerd deeg.**

**75%**

**Production jusqu'à 2500 pièces/heure**

**Production up to 2500 pieces/hour**

**Productie tot 2500 stukken/uur**

**DIVOTRAD**

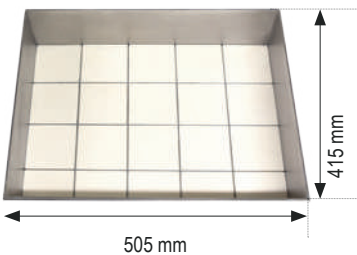

Tapis en silicone.

Silicon mat.

Silicone mat.



Plaque de tassage en matière rigide.

Hard pressing plate.

Harde drukplaat.

Option chassis en Inox

Option stainless steel body.

Optie RVS behuizing.

Reglage pression.

Pressure adjustment.

Drukregelaar.



Option: Echelle inox | Inox trolley  
Optie: RVS rek

Bacs   Bins   Bakken	14
Couvercles   Lids   Dekfels	14
Capacité   Capacity   Capaciteit	9,8 L (5 - 6 kg)

**Demandez notre catalogue grilles avec un large éventail de possibilités.**

**Ask for our catalogue of grids with a wide range of possibilities.**

**Vraag onze catalogus van de roosters, met tal van mogelijkheden.**

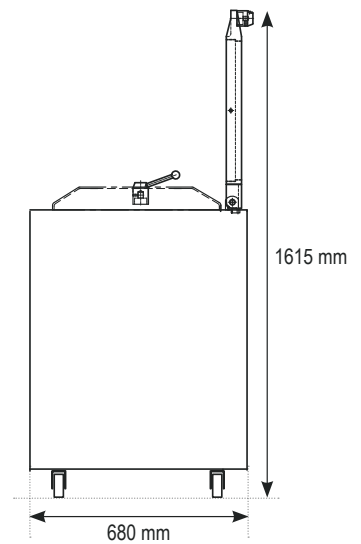
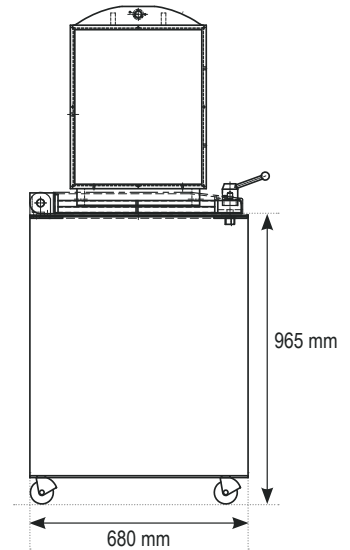

MODEL	DIVOTRAD	DIVO	DIVO
DIVISIONS   DIVISIONS   VERDELINGEN	20	20	20
CAPACITÉ par division   CAPACITY per division   CAPACITEIT per verdeling	Grid	100 - 950 g	100 - 950 g
PUISSANCE MOTEUR   MOTOR POWER   MOTORVERMOGEN	1,1 kW	1,1 kW	1,1 kW
POIDS NET MACHINE   NET WEIGHT MACHINE   NETTOGEWICHT MACHINE	285 kg	265 kg	265 kg
VOLTAGE   VOLTAGE   SPANNING	3Ph x 230/400V 50Hz		
OPTION ECHELLE   OPTION TROLLEY   OPTIE REK	✓	✓	✓
OPTION CHASSIS EN INOX   OPTION BODY IN STAINLESS STEEL   OPTIE BEHUIZING IN RVS	✓	✓	✓